

# Flow



## Proving Tanks (Tank Provers)

Proving Tanks or Tank Provers are precision made, open volumetric calibrating measures. They enable on-site calibration of liquid flow meters, master meters and vehicle tanks, with a high degree of accuracy and reliability.

### DESIGN FEATURES

- Rugged and fully welded construction
- Displacement tube for accurate volumetric adjustment
- Internal baffle plate prevents vortex formation and related trapping of air
- Provision to mount thermometers and level bottle for accurate liquid measurement
- Fixed or mobile versions with or without unloading pump and motor

### PRINCIPLE OF OPERATION

Proving Tanks are designed and manufactured in accordance with Indian Standard IS:2341 and Manual of Weights & Measures.

A Proving Tank consists of a cylindrical shell welded between two conical ends, which ensures smooth flow of liquid while draining the tank. Fitted to the bottom cone is a T-joint (where inlet and outlet isolation valves can be fitted) and a drain valve to assist in filling and draining of the tank. The top cone is fitted with a neck tube, having a conical top cover to prevent ingress of dirt in the tank.

A graduated glass tube is externally fitted to the neck tube, which indicates the liquid level in the neck tube. Graduations on the tube correspond to the volume per unit height of the neck tube.

The cylindrical shell has a manhole fitted with a bolted cover, which can be opened for internal inspection, painting, etc. A displacement tube arrangement is provided on the top cone to adjust the internal tank volume with the tank capacity mark on the graduated glass tube. For accurate adjustment of tank level, rest pad is fixed to the top cone for keeping level bottles. The body also has two thermowells capable of accepting mercury in steel type thermometers.

A baffle plate provided at the point of liquid entry in the bottom cone, prevents swirl or vortex formation and related trapping of air in the liquid. The entire tank is erected on a sturdy steel channel frame, which can be either grouted (for a fixed Proving Tank) or bolted to a movable trolley (in case of a mobile Proving Tank). In the latter case, the trolley comes with a tow bar and levelling screw jacks. The choice of a centrifugal pump with motor to fill or drain the liquid is optional, both for fixed or mobile tanks.



### APPLICATIONS

- Calibration of field mounted liquid flow meters or master meters
- Vehicle tank calibration
- Calibration of bulk measures

### PROVING TANK CALIBRATION

Before the calibration of the Proving Tank, it has to be ensured that the loading and unloading valves at the bottom and the drain valve are closed. The manhole cover is securely bolted and the displacement tube is inserted to approximately half of its length into the tank. With the help of level bottles, the tank is correctly levelled.

It is generally recommended to use a light petroleum product for tank calibration to minimize aeration of the liquid. Using verified measures of 10 ltrs. or 20 ltrs., liquid equal to the tank capacity is poured into the Proving Tank. The liquid level, as seen in the graduated glass tube, is noted. If the level of liquid does not match with the tank capacity mark on the graduated glass tube, the displacement tube is either inserted or retracted, to exactly match the liquid level with the tank capacity mark on the graduated glass tube. Tank calibration at this stage is complete.

The displacement tube, manhole cover and the graduated glass are then sealed.

### **CALIBRATING A FLOW METER USING FIXED PROVING TANK**

The field mounted flow meter is mounted in the pipeline carrying liquid into the Proving Tank. The Proving Tank is filled once or twice to purge all air from the system, stabilise temperature and wet the internal surface.

A quantity of liquid equivalent to the tank capacity is then passed through the flow meter into the tank. While doing this, the average temperature of liquid in the tank and the temperature of liquid flowing through the flow meter is noted. Since liquids, essentially petroleum products, expand (or contract) with increase (or decrease) in temperature, a temperature correction is applied to the liquid volume received in the tank, based on the temperature difference of the liquid in the tank and of liquid flowing through the flow meter. Liquids are also compressible, hence a pressure correction is applied on

the volume received in the tank based on difference of pressure in the Proving Tank, which is at atmospheric pressure and the pressure gauge reading at the flow meter inlet. The Proving Tank volume also slightly changes due to metal expansion or contraction, particularly if the temperature of liquid in the tank is different than the temperature at which it has been calibrated. After applying the various corrections, the final corrected volume is compared with flow meter reading and the flow meter error factor calculated.

### **CALIBRATING A FLOW METER USING MOBILE PROVING TANK**

The Proving Tank is towed and positioned in the loading bay or in an appropriate position, in order to direct the flow meter's liquid easily into the proving tank neck tube using a rubber hose. The tank is levelled correctly with the help of screw jacks provided. The bottom discharge valves alongwith the drain valve are closed. Procedure for proving the flow meter is now exactly the same as that for a fixed Proving Tank.

### **SPECIFICATIONS**

Type	: Open volumetric prover (conforms to IS:2341-1963)
Capacity	: 50, 100, 200, 500, 1000, 1500, 2000 and 5000 litres
Gauge Glass Resolution	: $\pm 0.1\%$ of tank capacity
Displacement Tube Volume	: $\pm 0.5\%$ of tank capacity
Thermometers	: Mercury in steel 0°C to 50°C
Trolley	: 2 tons, 4 tons and 6 tons capacity (for Mobile Proving Tank)

#### ***Optional Accessories***

Isolation Valves	: 2" / 3" Taper Plug Valves
Unloading Pump & Motor	: Centrifugal pump with 21 m <sup>3</sup> /hr discharge at 20 mtrs. head with flame-proof motor
(Specific request of pump capacity can be entertained)	

### **MATERIALS OF CONSTRUCTION**

Body	: Carbon steel (internally epicoated) Stainless Steel
Displacement Tube	: Carbon steel (zinc plated / yellow passivated) Stainless Steel
Graduated Glass	: Borosil glass
Thermowells	: Carbon steel
Drain Valve	: Carbon Steel Stainless Steel
Structural Members	: Carbon steel

### **MODEL DESIGNATION**

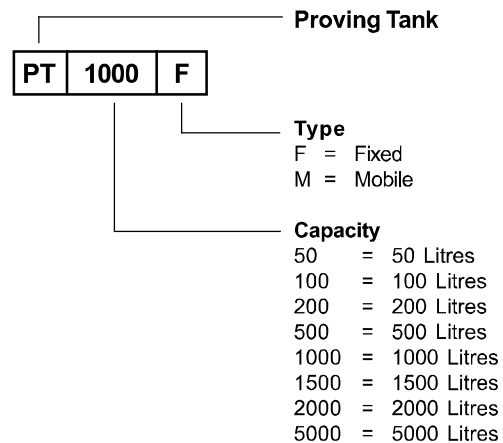

### FIXED PROVING TANK

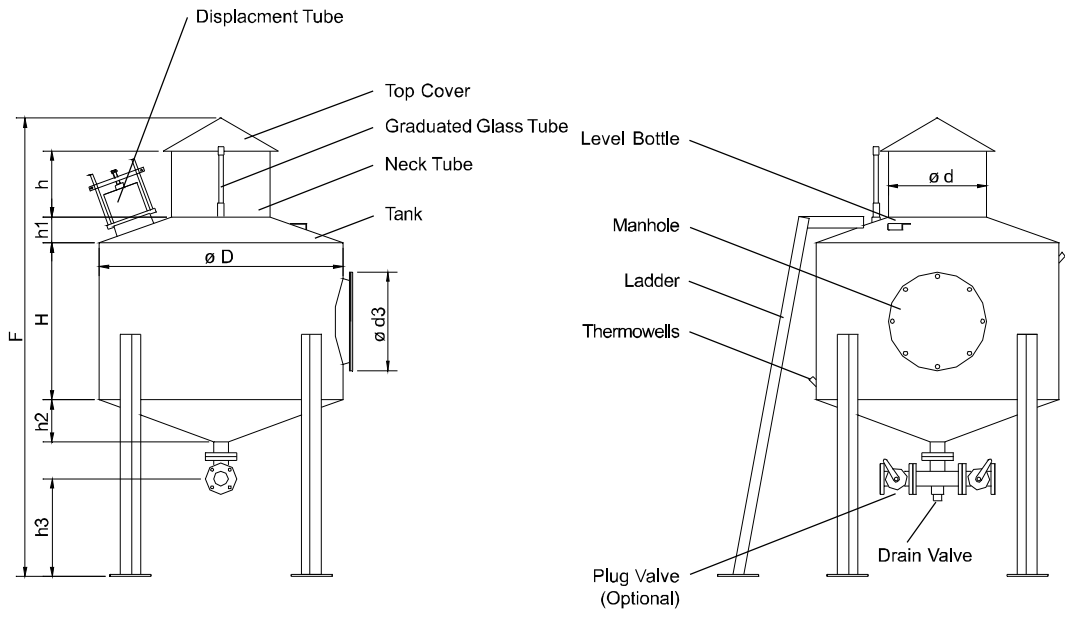

### MOBILE PROVING TANK

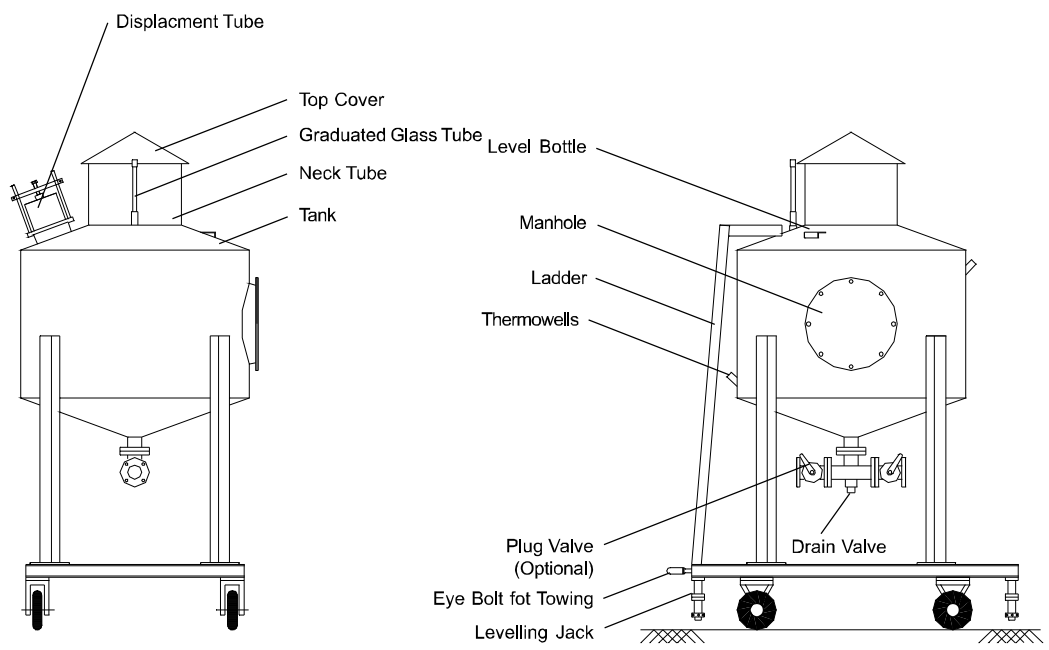



Custom Designed Mobile Skid Mounted Proving System

- Specifications are subject to change without notice.
- All dimensions are in mm unless otherwise specified.

Pub. No. 002  
Issue 2 Rev 1 12-2015

## ***Vermont Technologies Pvt. Ltd.***

Corporate Office & Operations:

Plot No: PAP- A-8/6, "A" Block, Phase IV, MIDC Chakan, Opp Mahindra Vehicle, Dist:Pune- 410501

Tel. : +91 9168179461 / +91 9168176683

Email : [ho@vermonttechnologies.co.in](mailto:ho@vermonttechnologies.co.in)

Website : [www.vermonttechnologies.co.in](http://www.vermonttechnologies.co.in)