

# Tank Fitting

## Flame Arresters



### SERIES 8350

Flame Arrestors prevent the passage of flames in storage vessels and along associated pipework systems and have applications in a wide range of industries including petroleum and petrochemicals, gas, marine and sewage treatment.

### INSTALLATION

Series 8350 Flame Arrestors should be mounted with the axis vertical and as close as possible to the potential source of ignition.

Series 8360 Flame Arrestors have been designed for fitting to the down-turned end of free vent pipes.

### CONSTRUCTION

Series 8350 Flame Arrestor consists of a tube bank made up of spirally wound alternate layers of flat and corrugated stainless steel sheets, built around a solid core. The tube bank offers a multiplicity of small holes parallel to the line of flow.

The tube element is retained between two flanged end sections and contained within an outer shell. (See Fig.1)

Flame Arrestor can be fitted with a weather hood. (See Fig.2)

### FEATURES

#### Crimped Ribbon Element Design

The corrugated *crimped ribbon* design of the Series 8350 Flame Arrestor element enables it to be manufactured to very close tolerances and hence can be efficiently size selected to suit the widest range of applications and flow parameters. Pressure drop across the Flame Arrestor is very low and hence it is suitable for high gas flow rates.

### OPTIONS AVAILABLE

#### Weather Hood

Weather hoods are available for fitting to all sizes of Flame Arrestors, for use where the arrestors are mounted in exposed position, e.g. on vessel roofs.



### SIZING AND SELECTION

Due to varying degrees of hazard, it is necessary to very carefully assess the type and capacity of Flame Arrestor required for safe operation.

A detailed application form, as specified within this catalogue, should be completed for every proposed Flame Arrestor application and returned to us to assist in the correct sizing of the Flame Arrestor required to suit each application.

### SPECIFICATIONS

Sizes	: 50 mm (2")	80 mm (3")
	100 mm (4")	150 mm (6")
	200 mm (8")	250 mm (10")
	300 mm (12")	

End Connections : ASA 150 FF

# FLAME ARRESTOR

## SERIES 8350

### DIMENSIONS

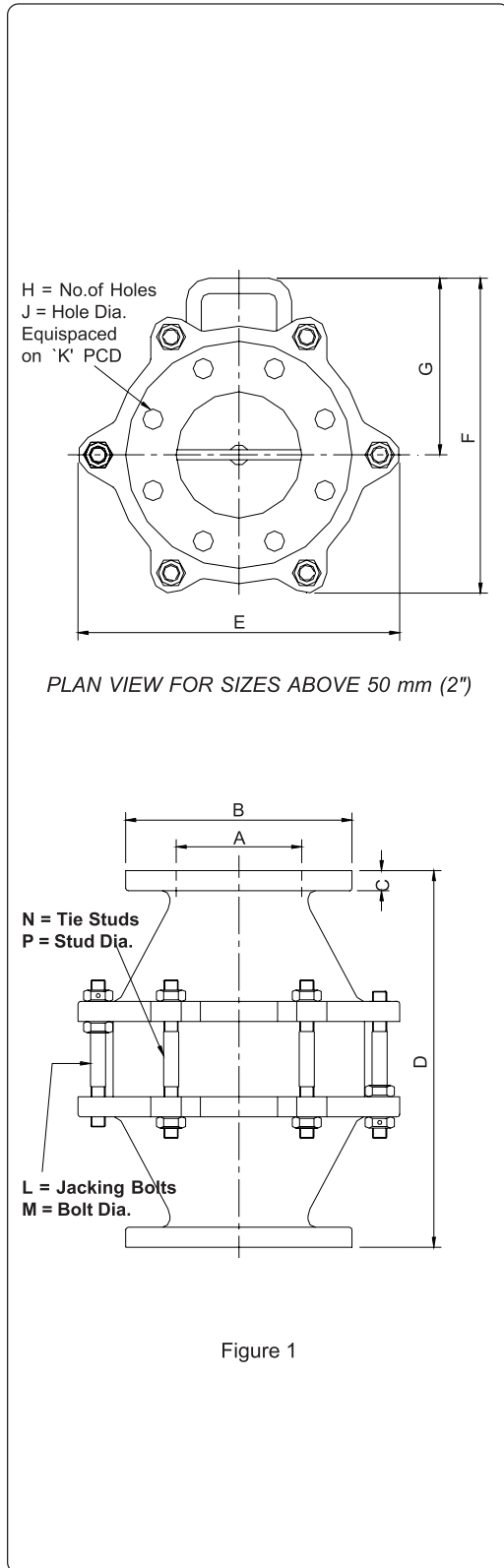

NOMINAL SIZE		A		B		C		D	
mm	inch	mm	inch	mm	inch	mm	inch	mm	inch
50	2	57	2-1/4	165	6-1/2	22	7/8	333	13-1/8
80	3	79	3-1/8	200	7-7/8	22	7/8	406	16
100	4	105	4-1/8	229	9	22	7/8	470	18-1/2
150	6	159	6-1/4	286	11-1/4	25	1	521	20-1/2
200	8	210	8-1/4	340	13-3/8	25	1	641	25-1/4
250	10	260	10-1/4	432	17	35	1-3/8	772	30-7/8
300	12	305	12	486	19-1/8	35	1-3/8	940	37

NOMINAL SIZE		E		F		G		H
mm	inch	mm	inch	mm	inch	mm	inch	No. of Holes
50	2	184	7-1/4	219	8-5/8	111	4-3/8	4
80	3	267	10-1/2	248	9-3/4	146	5-3/4	4
100	4	318	12-1/2	300	11-7/8	165	6-1/2	8
150	6	410	16-1/8	406	16	229	9	8
200	8	508	20	495	19-1/2	276	10-7/8	8
250	10	641	25-1/4	638	25-1/8	330	13	12
300	12	762	30	762	30	391	15-3/8	12

NOMINAL SIZE		J		K		L	M	N	P
mm	inch	mm	inch	mm	inch	No.	mm	No.	mm
50	2	19	3/4	121	4-3/4	2	16	1	16
80	3	19	3/4	152	6	2	16	2	16
100	4	19	3/4	191	7-1/2	2	16	4	16
150	6	22	7/8	241	9-1/2	2	20	4	20
200	8	22	7/8	298	11-3/4	2	20	4	20
250	10	24	15/16	362	14-1/4	2	24	6	24
300	12	24	15/16	432	17	2	24	6	24

**PERFORMANCE OF FLAME ARRESTOR  
FLOW CAPACITY**

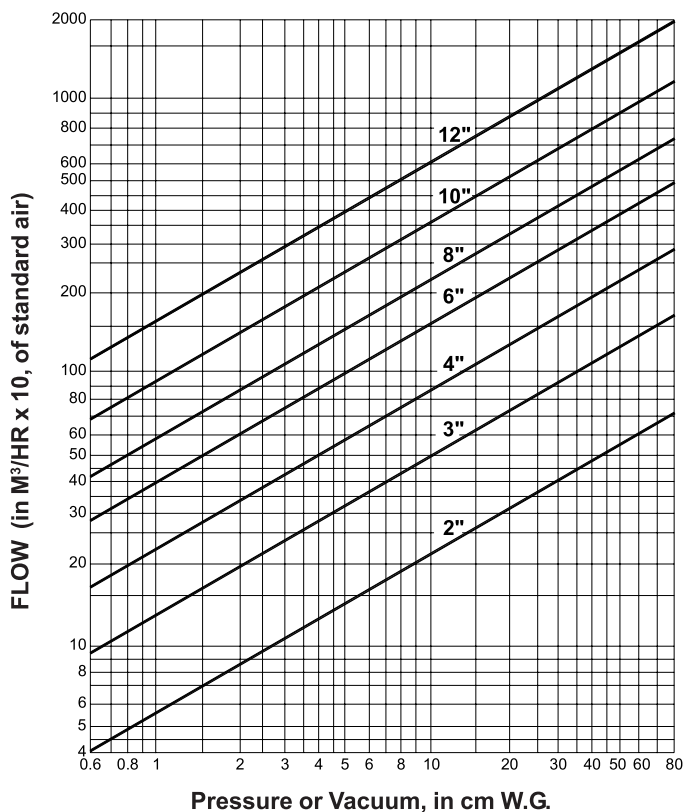

*(Above graph is applicable for clean Tube Banks only)*

**FLAME ARRESTOR  
WITH HOOD**

**DIMENSIONS**

NOMINAL SIZE		A		B	
mm	inch	mm	inch	mm	inch
50	2	445	17-1/2	305	12
80	3	534	21	343	13-1/2
100	4	648	25-1/2	394	15-1/2
150	6	700	27-1/2	394	15-1/2
200	8	832	32-3/4	508	20
250	10	1000	39-3/8	635	25
300	12	1200	47	750	29-1/2

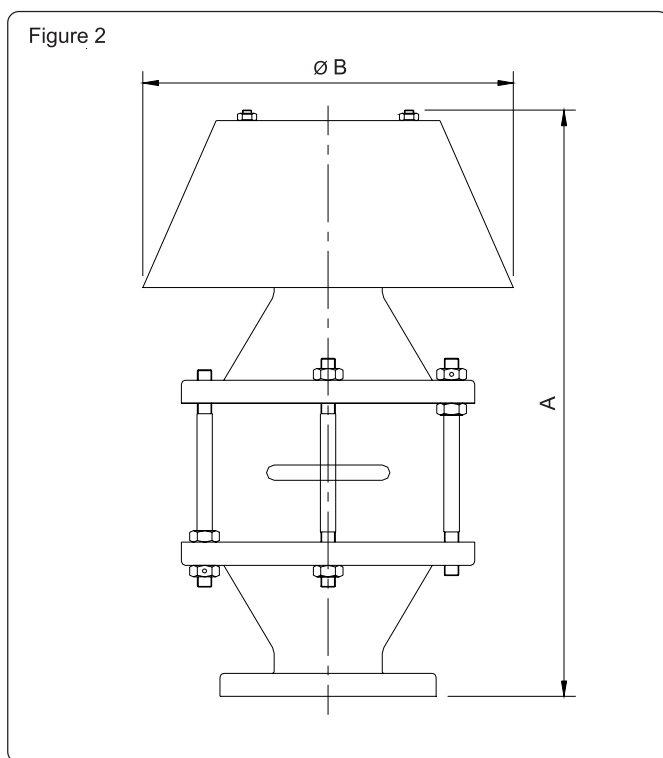

## MATERIALS OF CONSTRUCTION

Body	: Aluminium alloy LM-25
Shell	: Aluminium alloy LM-25
Core Tube	: Aluminium
Tube Bank	: Stainless Steel AISI 304
Hood	: Galvanised Steel
Hardware	: Mild Steel
(Optional)	(Zinc Plated / Yellow Passivated)

## APPLICATION DATA - IMPORTANT CRITERIA FOR SIZING SELECTION

Due to varying degrees of hazard, it is necessary to very carefully assess the type and capacity of Flame Arrestor required for safe operation.

A detailed application form, to include information as listed below, should be completed and returned to us for each and every proposed Flame Arrestor application to assist in the correct sizing of the Flame Arrestor required to suit each application.

1. Enquiry / order number
2. Analysis of gases and/or vapours - % by volume or tank contents
3. Flash point
4. Storage tank capacity (if applicable)
5. Max. filling and emptying rates for storage tanks
6. Max. static pressure at Flame Arrestor
7. Max. temperature at Flame Arrestor
8. Min. temperature at Flame Arrestor
9. Max. rate of flow (by volume)
10. Acceptable pressure drop
11. In-line or End-of-line type
12. If In-line type, distance of Flame Arrestor from source of ignition
13. Type and size of flange or threads
14. Material for housing
15. Material for element
16. Advise if continuous burning on element possible
17. Special requirements (if any)

## MODEL DESIGNATION

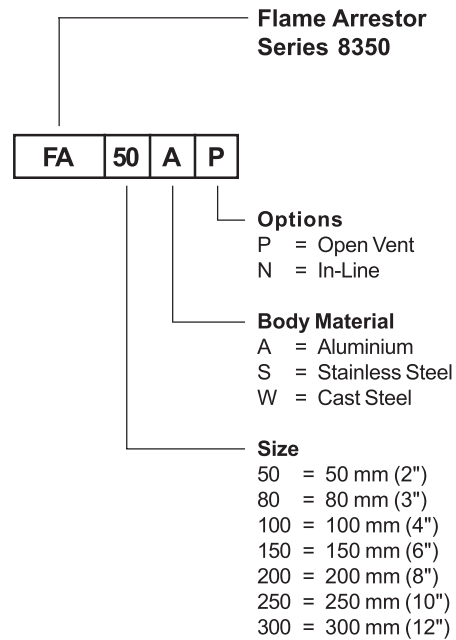

\* Specifications are subject to change without notice.  
\* All dimensions are in mm unless otherwise specified.

**Vermont Technologies Pvt. Ltd.**

**Corporate Office & Operations:**

Plot No. PAP-A-8/6, "A" Block, Phase IV, MIDC Chakan, Opp Mahindra Vehicle, Dist. Pune - 410 501.

Tel : +91 9168179461 / +91 9168176683

E-mail : [ho@vermonttechnologies.co.in](mailto:ho@vermonttechnologies.co.in)

Website : [www.vermonttechnologies.co.in](http://www.vermonttechnologies.co.in)