

Bowser (Tank Truck) Dispenser Application

Accurate Bowser mounted P. D. Flow Meters
Fuel, Ethanol, Spirits, Solvents & other liquids...

Salient Features:

- *High Accuracy & Repeatability of 0.02%*
- *Approved by Weights & Measures, Legal Metrology*
- *Customized layout arrangement*
- *Electronic & Mechanical counter options*
- *Printing & Computer interface integration possible*
- *Reliable, hassle-free maintenance and fast service*

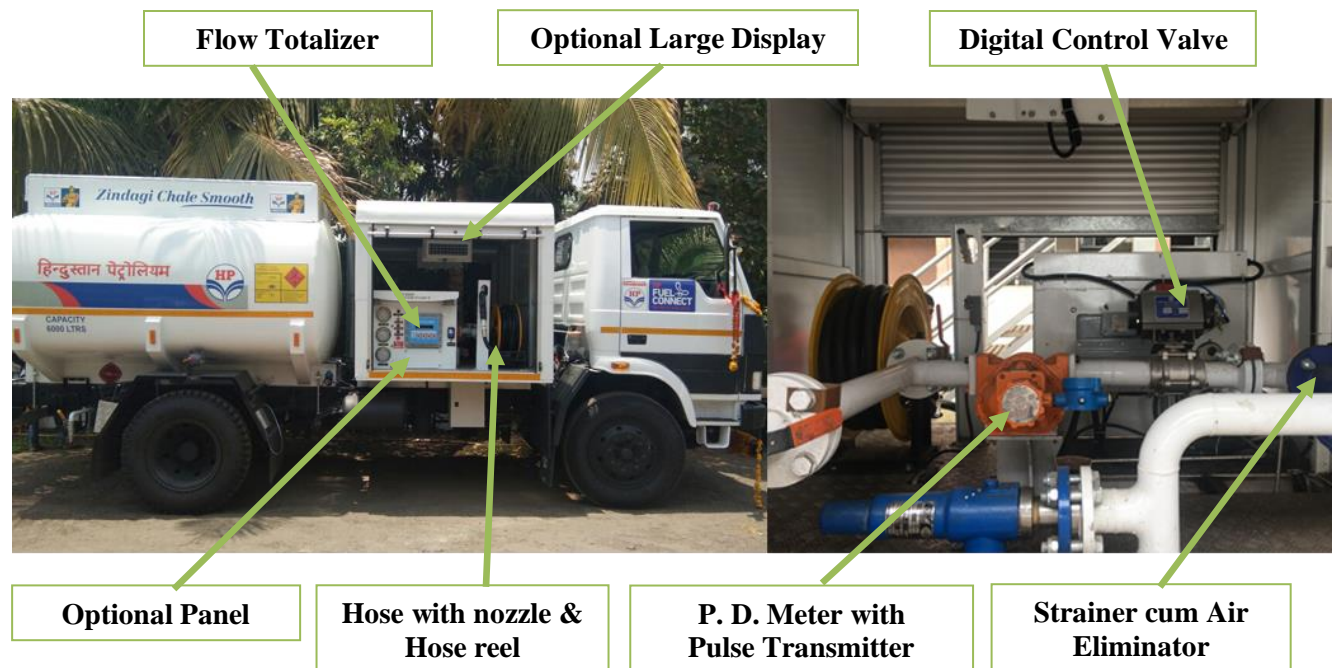

P. D. Flowmeter in Bowser Truck dispensing application



Corporate Office & Operations:

Plot No. PAP-A-8/6, "A" Block, Phase IV, MIDC Chakan, Opp Mahindra Vehicle,
Dist. Pune - 410 501, Maharashtra.
Tel : +91 9168179461/ 9168176683
E-mail : ho@vermonttechnologies.co.in
Website : www.vermonttechnologies.co.in

Truck Meter (Diesel Bowser/ Refueller/ Mobile Dispenser)



1. P. D. Flowmeter
2. Pulse Transmitter
3. Digital Control Valve
4. Strainer cum Air Eliminator
5. Ball Valve
6. Pressure Gauge
7. Flow Totaliser
8. PTO Pump
9. Piping Arrangement
10. Hose with Nozzle and hose reel

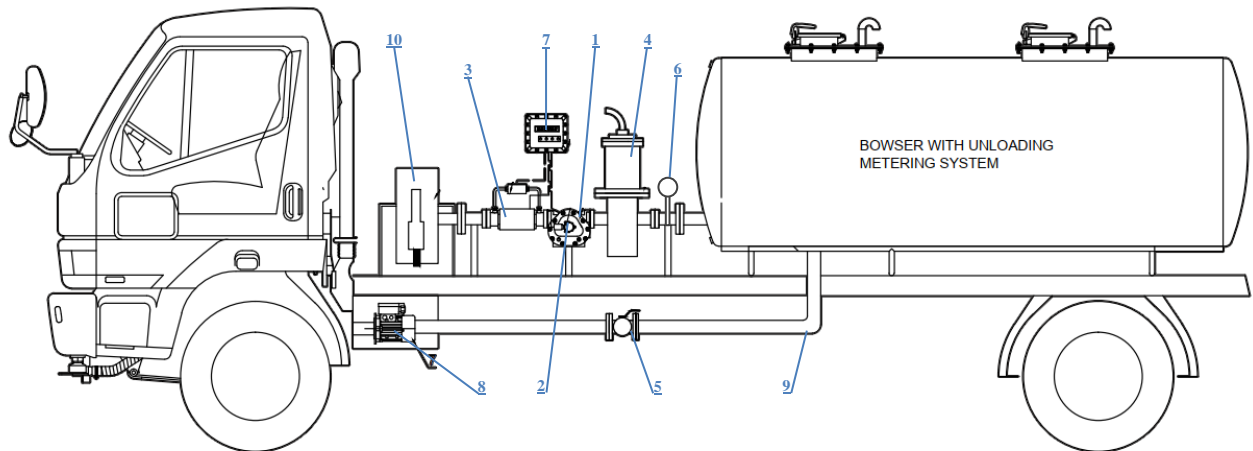

Note: -

1. PTO driven or battery driven Pump & Motor configurations as per requirement
2. Layout of system is based on bowser or tank truck arrangement



Corporate Office & Operations:

Plot No. PAP-A-8/6, "A" Block, Phase IV, MIDC Chakan, Opp Mahindra Vehicle,
Dist. Pune - 410 501, Maharashtra.
Tel : +91 9168179461/ 9168176683
E-mail : ho@vermonttechnologies.co.in
Website : www.vermonttechnologies.co.in